

(12) **United States Patent**  
**Hastings et al.**

(10) **Patent No.:** **US 6,599,230 B2**  
(45) **Date of Patent:** **\*Jul. 29, 2003**

- (54) **INTRAVASCULAR RADIATION DELIVERY SYSTEM**
- (75) Inventors: **Roger N. Hastings**, Maple Grove, MN (US); **Thomas R. Hektner**, Medina, MN (US); **Stewart M. Kume**, Belmont, CA (US)

(73) Assignee: **SciMed Life Systems, Inc.**, Maple Grove, MN (US)

(\*) Notice: Subject to any disclaimer, the term of this patent is extended or adjusted under 35 U.S.C. 154(b) by 127 days.

This patent is subject to a terminal disclaimer.

(21) Appl. No.: **09/808,315**

(22) Filed: **Mar. 14, 2001**

(65) **Prior Publication Data**

US 2001/0023308 A1 Sep. 20, 2001

**Related U.S. Application Data**

(63) Continuation of application No. 08/782,471, filed on Jan. 10, 1997, now Pat. No. 6,234,951, which is a continuation-in-part of application No. 08/608,655, filed on Feb. 29, 1996, now Pat. No. 5,882,290.

- (51) **Int. Cl.**<sup>7</sup> ..... **A61N 5/00**  
(52) **U.S. Cl.** ..... **600/3**; 604/103.07  
(58) **Field of Search** ..... 600/1-8; 606/191, 606/194; 604/103.07, 103.08

(56) **References Cited**

**U.S. PATENT DOCUMENTS**

1,442,051 A	1/1923	Cummings	
2,546,761 A	3/1951	Loftus	128/1.2
2,862,108 A	11/1958	Meilink	250/106
2,955,208 A	10/1960	Stevens	250/108
3,060,924 A	10/1962	Rush	128/1.2
3,147,383 A	9/1964	Prest	250/108

3,324,847 A	6/1967	Zoumboulis	128/1.2
3,505,991 A	4/1970	Hellerstein et al.	128/1.1
3,643,096 A	2/1972	Jeffries, Jr. et al.	250/108 R
3,669,093 A	6/1972	Sauerwein et al.	128/1.1
3,674,006 A	7/1972	Holmer	600/7
3,750,653 A	8/1973	Simon	128/1.2

(List continued on next page.)

**FOREIGN PATENT DOCUMENTS**

CA	2166915 A	8/1996
DE	9102312.2	8/1992
DE	195 26 680 A1	1/1997

(List continued on next page.)

**OTHER PUBLICATIONS**

Fackelmann, "Harbinger of a Heart Attack", *Science News*, vol. 151, Jun. 14, 1997, pp. 374-375.

(List continued on next page.)

*Primary Examiner*—John P. Lacyk

(74) *Attorney, Agent, or Firm*—Christensen O'Connor Johnson Kindness PLLC

(57) **ABSTRACT**

An intravascular radiation delivery system including a catheter, a radiation source disposed in an open-ended lumen in the catheter and a closed-ended sheath surrounding the radiation source so as to prevent blood and other fluids from coming into contact with the radiation source. Preferably, the open-ended lumen is centered in the balloon for uniform radiation delivery. The catheter may include a blood perfusion lumen under the balloon or around the balloon. The open-ended lumen in the catheter may have a reduced diameter adjacent the distal end of the catheter to prevent the radiation source from exiting the lumen. Methods of using the radiation delivery system are also disclosed.

An alternative method of delivering radiation to a treatment site inside the vasculature of a patient using a gas-filled balloon catheter and a radiation source disposed in the balloon catheter. The treatment site is exposed to radiation, preferably beta radiation, through the gas-filled balloon.

**15 Claims, 8 Drawing Sheets**

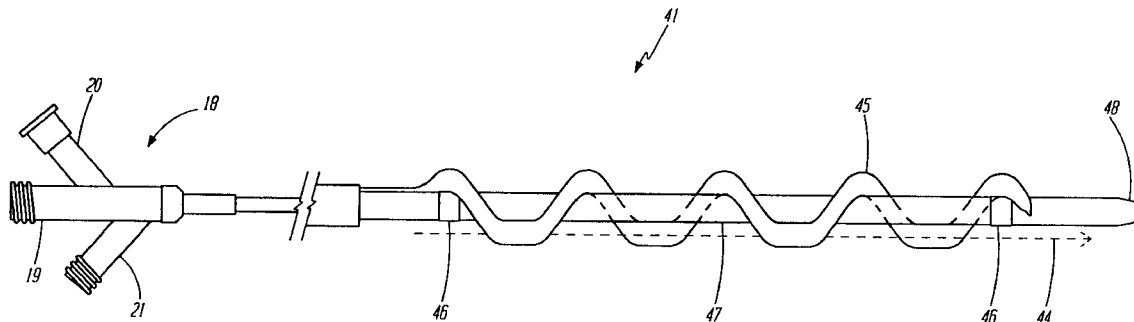

U.S. PATENT DOCUMENTS							
3,811,426 A	5/1974	Culver et al. ....	128/1.2	5,532,122 A	7/1996	Drukier .....	435/5
3,861,380 A	1/1975	Chassagne et al. ....	128/1.2	5,538,494 A	7/1996	Matsuda .....	600/1
3,866,050 A	2/1975	Whitfield .....	250/497	5,540,659 A	7/1996	Teirstein .....	604/104
3,927,325 A	12/1975	Hungate et al. ....	250/435	5,556,389 A	9/1996	Liprie .....	604/264
3,970,073 A	7/1976	Greene .....	128/1.2	5,575,749 A	11/1996	Liprie .....	600/3
4,096,862 A	6/1978	DeLuca .....	128/348	5,605,530 A	2/1997	Fischell et al. ....	600/3
4,220,864 A	9/1980	Sauerwein et al. ....	250/497	5,611,767 A	3/1997	Williams .....	600/2
4,225,790 A	9/1980	Parsons, Jr. et al. ....	250/497	5,616,114 A	4/1997	Thornton et al. ....	600/3
4,244,357 A	1/1981	Morrison .....	128/1.2	5,618,266 A	4/1997	Liprie .....	604/21
4,281,252 A	7/1981	Parsons, Jr. et al. ....	250/497	5,624,372 A	4/1997	Liprie .....	600/3
4,314,157 A	2/1982	Gaines .....	250/497	5,643,171 A	7/1997	Bradshaw et al. ....	600/1
4,364,376 A	12/1982	Bigham .....	128/1.1	5,649,924 A	7/1997	Everett et al. ....	606/15
4,402,308 A	9/1983	Scott .....	128/1.2	5,653,683 A	8/1997	D'Andrea .....	604/21
4,584,991 A	4/1986	Tokita et al. ....	128/1.1	5,662,580 A	9/1997	Bradshaw et al. ....	600/3
4,588,395 A	5/1986	Lemelson .....	604/59	5,674,177 A	10/1997	Hehrlein et al. ....	600/3
4,631,415 A	12/1986	Sauerwein et al. ....	250/497.1	5,683,345 A	11/1997	Waksman et al. ....	600/3
4,697,575 A	10/1987	Horowitz .....	128/1.2	5,688,220 A	11/1997	Verin et al. ....	600/1
4,702,228 A	10/1987	Russell, Jr. et al. ....	128/1.2	5,707,332 A	1/1998	Weinberger .....	600/3
4,706,652 A	11/1987	Horowitz .....	128/1.2	5,713,828 A	2/1998	Coniglione .....	600/7
4,763,642 A	8/1988	Horowitz .....	128/1.2	5,720,717 A	2/1998	D'Andrea .....	604/21
4,763,671 A	8/1988	Goffinet .....	128/786	5,722,984 A	3/1998	Fischell et al. ....	606/198
4,782,834 A	11/1988	Maguire et al. ....	128/344	5,728,042 A	3/1998	Schwager .....	600/3
4,784,116 A	11/1988	Russell, Jr. et al. ....	128/1.2	5,730,698 A	3/1998	Fischell et al. ....	600/3
4,815,449 A	3/1989	Horowitz .....	600/7	5,782,740 A	7/1998	Schneiderman .....	600/1
4,819,618 A	4/1989	Liprie .....	600/7	5,782,742 A	7/1998	Crocker et al. ....	600/3
4,851,694 A	7/1989	Rague et al. ....	250/497.1	5,795,286 A	8/1998	Fischell et al. ....	600/3
4,861,520 A	8/1989	van't Hooft et al. ....	252/644	5,800,333 A	9/1998	Liprie .....	600/3
4,881,937 A	11/1989	van't Hooft et al. ....	600/3	5,803,895 A	9/1998	Kronholz et al. ....	600/3
4,897,076 A	1/1990	Puthawala et al. ....	600/7	5,807,231 A	9/1998	Liprie .....	600/3
4,936,823 A	6/1990	Colvin et al. ....	600/7	5,816,259 A	10/1998	Rose .....	128/898
4,963,128 A	10/1990	Daniel et al. ....	600/7	5,816,999 A	10/1998	Bischoff et al. ....	600/3
4,969,863 A	11/1990	van't Hooft et al. ....	600/3	5,820,553 A	10/1998	Hughes .....	600/426
4,976,266 A	12/1990	Huffman et al. ....	128/659	5,833,593 A	11/1998	Liprie .....	600/3
4,976,680 A	12/1990	Hayman et al. ....	600/7	5,840,008 A	11/1998	Klein et al. ....	600/3
4,976,690 A	12/1990	Solar et al. ....	604/96	5,840,009 A	11/1998	Fischell et al. ....	600/3
4,994,013 A	2/1991	Suthanthiran et al. ....	600/8	5,840,064 A	11/1998	Liprie .....	604/96
5,030,194 A	7/1991	Van't Hooft .....	600/3	5,843,163 A	12/1998	Wall .....	623/1
5,032,113 A	7/1991	Burns .....	604/96	5,849,036 A	12/1998	Zarate .....	623/1
5,059,166 A	10/1991	Fischell et al. ....	600/3	5,851,171 A	12/1998	Gasson .....	600/3
5,084,001 A	1/1992	Van't Hooft et al. ....	600/3	5,851,172 A	12/1998	Bueche et al. ....	600/7
5,084,002 A	1/1992	Liprie .....	600/7	5,855,546 A	1/1999	Hastings et al. ....	600/3
5,092,834 A	3/1992	Bradshaw et al. ....	600/7	5,857,956 A	1/1999	Liprie .....	600/7
5,103,395 A	4/1992	Spako et al. ....	364/413.26	5,863,284 A	1/1999	Klein .....	600/3
5,106,360 A	4/1992	Ishiwara et al. ....	600/2	5,863,285 A	1/1999	Coletti .....	600/3
5,120,973 A	6/1992	Rohe et al. ....	250/497.1	5,865,720 A	2/1999	Hastings et al. ....	600/3
5,139,473 A	8/1992	Bradshaw et al. ....	600/3	5,871,436 A	2/1999	Eury .....	600/3
5,141,487 A	8/1992	Liprie .....	600/7	5,871,437 A	2/1999	Alt .....	600/3
5,147,282 A	9/1992	Kan .....	600/1	5,873,811 A	2/1999	Wang et al. ....	600/5
5,163,896 A	11/1992	Suthanthiran et al. ....	600/8	5,879,282 A	3/1999	Fischell et al. ....	600/3
5,176,617 A	1/1993	Fischell et al. ....	600/3	5,882,290 A	3/1999	Kume .....	600/3
5,183,455 A	2/1993	Hayman et al. ....	600/7	5,882,291 A	3/1999	Bradshaw et al. ....	600/3
5,199,939 A	4/1993	Dake et al. ....	600/3	5,891,091 A	4/1999	Teirstein .....	604/104
5,213,561 A	5/1993	Weinstein et al. ....	600/3	5,897,573 A	4/1999	Rosenthal et al. ....	606/224
5,267,960 A	12/1993	Hayman et al. ....	604/106	5,899,882 A	5/1999	Waksman et al. ....	604/96
5,282,781 A	2/1994	Liprie .....	600/3	5,906,573 A	5/1999	Aretz .....	600/3
5,302,168 A	4/1994	Hess .....	600/3	5,910,101 A	6/1999	Andrews et al. ....	600/3
5,344,383 A	9/1994	Liping .....	600/3	5,910,102 A	6/1999	Hastings .....	600/3
5,354,257 A	10/1994	Roubin et al. ....	600/7	5,913,813 A	6/1999	Williams et al. ....	600/3
5,370,685 A	12/1994	Stevens .....	623/2	5,916,143 A	6/1999	Apple et al. ....	600/3
5,391,139 A	2/1995	Edmundson .....	600/7	5,919,126 A	7/1999	Armini .....	600/3
5,395,300 A	3/1995	Liprie .....	600/3	5,924,973 A	7/1999	Weinberger .....	600/3
5,405,309 A	4/1995	Carden, Jr. ....	600/3	5,924,974 A	7/1999	Loffler .....	600/3
5,409,015 A	4/1995	Palermo .....	128/772	5,925,353 A	7/1999	Mosseri .....	424/178.1
5,411,466 A	5/1995	Hess .....	600/3	5,938,582 A	8/1999	Ciamacco, Jr. et al. ....	600/3
5,425,720 A	6/1995	Rogalsky et al. ....	604/198	5,947,889 A	9/1999	Hehrlein .....	600/3
5,429,582 A	7/1995	Williams .....	600/2	5,947,924 A	9/1999	Liprie .....	604/96
5,484,384 A	1/1996	Fearnot .....	600/3	5,947,958 A	9/1999	Woodard et al. ....	606/1.5
5,498,227 A	3/1996	Mawad .....	600/3	5,957,829 A	9/1999	Thornton .....	600/3
5,503,613 A	4/1996	Weinberger .....	600/3	5,961,439 A	10/1999	Chernomorsky et al. ....	600/4
5,503,614 A	4/1996	Liprie .....	600/7	5,967,966 A	10/1999	Kronholz et al. ....	600/3
				5,971,909 A	10/1999	Bradshaw et al. ....	600/3

5,976,106	A	11/1999	Verin et al. ....	604/96	EP	0 754 472	A2	1/1997
5,997,462	A	12/1999	Loffler .....	600/3	EP	0 754 473	A2	1/1997
5,997,463	A	12/1999	Cutrer .....	600/8	EP	0 593 136	B1	3/1997
6,010,445	A	1/2000	Armini et al. ....	600/3	EP	0 778 051	A1	6/1997
6,013,019	A	1/2000	Fischell et al. ....	600/3	EP	0 801 961	A2	10/1997
6,013,020	A	1/2000	Meloul et al. ....	600/7	EP	0 810 004		12/1997
6,019,718	A	2/2000	Hektner .....	600/3	EP	0 813 894	A2	12/1997
6,024,690	A	2/2000	Lee et al. ....	600/3	EP	0 629 380	B1	7/1998
6,030,333	A	2/2000	Sioshansi et al. ....	600/3	EP	0 865 803		9/1998
6,033,357	A	3/2000	Ciezki et al. ....	600/3	EP	0 904 798		3/1999
6,048,300	A	4/2000	Thornton et al. ....	600/7	EP	0 904 799		3/1999
6,050,930	A	4/2000	Teirstein .....	600/3	JP	10071210		3/1998
6,053,858	A	4/2000	Bueche et al. ....	600/3	JP	2000014810		1/2000
6,059,713	A	5/2000	Urick et al. ....	600/3	WO	WO 86/03124		6/1986
6,059,752	A	5/2000	Segal .....	604/107	WO	WO 92/00776		1/1992
6,059,812	A	5/2000	Clerc et al. ....	606/198	WO	WO 93/04735		3/1993
6,066,083	A	5/2000	Slater et al. ....	600/8	WO	WO 94/25106		11/1994
6,068,611	A	5/2000	Loffler et al. ....	604/101	WO	WO 94/26205		11/1994
6,071,227	A	6/2000	Popowski et al. ....	600/3	WO	WO 95/07732		3/1995
6,074,338	A	6/2000	Popowski et al. ....	600/3	WO	WO 95/19807		7/1995
6,077,213	A	6/2000	Ciezki et al. ....	600/3	WO	WO 96/06654		3/1996
6,093,142	A	7/2000	Ciamacco, Jr. ....	600/3	WO	WO 96/10436		4/1996
6,095,966	A	8/2000	Chornenky et al. ....	600/3	WO	WO 96/13303		5/1996
6,099,499	A	8/2000	Ciamacco, Jr. ....	604/103	WO	WO 96/14898		5/1996
6,117,064	A	9/2000	Apple et al. ....	600/3	WO	WO 96/17654		6/1996
6,120,533	A	9/2000	Fischell .....	623/1.11	WO	WO 96/22121		7/1996
6,132,358	A	10/2000	Glenn et al. ....	600/3	WO	WO 96/29943		10/1996
6,132,423	A	10/2000	Aita et al. ....	606/7	WO	WO 96/40352		12/1996
6,146,323	A	11/2000	Fischell .....	600/3	WO	WO 97/07740		3/1997
6,159,139	A	12/2000	Chiu .....	600/3	WO	WO 97/09937		3/1997
6,159,140	A	12/2000	Loeffler et al. ....	600/3	WO	WO 97/17029		5/1997
6,159,142	A	12/2000	Alt .....	600/3	WO	WO 97/18012		5/1997
6,159,143	A	12/2000	Lennox .....	600/4	WO	WO 97/19706		6/1997
6,176,821	B1	1/2001	Crocker et al. ....	600/3	WO	WO 97/25102		7/1997
6,179,789	B1	1/2001	Tu et al. ....	600/585	WO	WO 97/25103		7/1997
6,183,409	B1	2/2001	Armini .....	600/3	WO	WO 97/40889		11/1997
6,183,410	B1	2/2001	Jacobsen et al. ....	600/3	WO	WO 98/01183		1/1998
6,187,037	B1	2/2001	Satz .....	623/1.34	WO	WO 98/01184		1/1998
6,192,271	B1	2/2001	Hayman .....	604/21	WO	WO 98/01185		1/1998
6,196,963	B1	3/2001	Williams .....	600/3	WO	WO 98/01186		1/1998
6,196,964	B1	3/2001	Loffler et al. ....	600/7	WO	WO 98/11936		3/1998
6,196,996	B1	3/2001	Teirstein .....	604/104	WO	WO 98/16151		4/1998
6,210,312	B1	4/2001	Nagy .....	600/3	WO	WO 98/20935		5/1998
6,210,313	B1	4/2001	Eury .....	600/3	WO	WO 98/25674		6/1998
6,210,315	B1	4/2001	Andrews et al. ....	600/7	WO	WO 98/29049		7/1998
6,210,316	B1	4/2001	Slater et al. ....	600/8	WO	WO 98/30273		7/1998
6,231,494	B1	5/2001	Verin et al. ....	600/1	WO	WO 98/34681		8/1998
6,234,951	B1	5/2001	Hastings .....	600/3	WO	WO 98/36788		8/1998
					WO	WO 98/36790		8/1998
					WO	WO 98/36796		8/1998
					WO	WO 98/39052		9/1998
					WO	WO 98/39062		9/1998
					WO	WO 98/39063		9/1998
					WO	WO 98/40032		9/1998
					WO	WO 98/46309		10/1998
					WO	WO 98/55179		12/1998
					WO	WO 98/57706		12/1998
					WO	WO 99/01179		1/1999
					WO	WO 99/02219		1/1999
					WO	WO 99/04706		2/1999
					WO	WO 99/04856		2/1999
					WO	WO 99/10045		3/1999
					WO	WO 99/21615		5/1999
					WO	WO 99/21616		5/1999
					WO	WO 99/22774		5/1999
					WO	WO 99/22775		5/1999
					WO	WO 99/22812		5/1999
					WO	WO 99/22815		5/1999
					WO	WO 99/24116		5/1999
					WO	WO 99/24117		5/1999
					WO	WO 99/29354		6/1999

## FOREIGN PATENT DOCUMENTS

DE	197 54 870	A1	8/1998
DE	197 24 233	C1	12/1998
DE	197 07 727		7/1999
DE	197 58 234		7/1999
DE	198 25 563		12/1999
DE	198 25 999		12/1999
DE	198 26 000		12/1999
DE	198 29 444		1/2000
DE	198 29 447		1/2000
EP	0 152 124		8/1985
EP	0 158 630		10/1985
EP	0 433 011	A1	6/1991
EP	0 447 745	A2	9/1991
EP	0 466 681	A1	1/1992
EP	0 474 994		3/1992
EP	0 514 913	A2	11/1992
EP	0 633 041	A1	1/1995
EP	0 686 342	A1	12/1995
EP	0 688 580	A1	12/1995
EP	0 696 906	B1	2/1996
EP	0 749 764	A1	12/1996

WO	WO 99/29370	6/1999
WO	WO 99/29371	6/1999
WO	WO 99/30779	6/1999
WO	WO 99/34969	7/1999
WO	WO 99/36121	7/1999
WO	WO 99/39628	8/1999
WO	WO 99/40962	8/1999
WO	WO 99/40970	8/1999
WO	WO 99/40971	8/1999
WO	WO 99/40972	8/1999
WO	WO 99/40973	8/1999
WO	WO 99/40974	8/1999
WO	WO 99/42162	8/1999
WO	WO 99/42163	8/1999
WO	WO 99/42177	8/1999
WO	WO 99/44686	9/1999
WO	WO 99/44687	9/1999
WO	WO 99/49935	10/1999
WO	WO 99/56825	11/1999
WO	WO 99/56828	11/1999
WO	WO 99/61107	12/1999
WO	WO 99/62598	12/1999
WO	WO 99/66979	12/1999
WO	WO 00/03292	1/2000
WO	WO 00/04838	2/2000
WO	WO 00/04953	2/2000
WO	WO 00/09212	2/2000
WO	WO 00/29501	5/2000
WO	WO 00/37137	6/2000
WO	WO 00/45892	8/2000
WO	WO 00/54836	9/2000
WO	WO 00/57956	10/2000
WO	WO 00/67845	11/2000

WO	WO 00/78394	12/2000
WO	WO 00/78395	12/2000

## OTHER PUBLICATIONS

Lommatzsch et al., "Radiation effects on the optic nerve observed after brachytherapy of choroidal melanomas with 106Ru/106Rh plaques", *Graefe's Arch. Clin. Exp. Ophthalmology* vol. 232, pp. 482-487, 1994.

*Radiotherapy of Intraocular and Orbital Tumors*, Springer-Verlag publishers, Berlin Heidelberg and New York, copyright 1993, pp. 23-30 and 363-367.

Raloff, "Nuclear Medicine Gets Friendlier—Experimental Therapies Seek to Poison Just the Disease", *Science News*, Bol. 152, Jul. 19, 1997, pp. 40-41.

Sealy, R. et al., "The Treatment of Cancer of the Uvula and Soft Palate with Interstitial Radioactive Wire Implants," *Int. J. Radiation Oncology Biol. Phys.*, vol. 10, Oct. 1984, pp. 1951-1955.

Sinclair, W.K. et al. "Artificial Radioactive Sources for Interstitial Therapy," Source Unknown, Aug. 1952, pp. 417-419.

Wallace, D.M. et al., "Radioactive Tantalum Wire Implantation as a Method of Treatment for Early Carcinoma of the Bladder," Source Unknown, Aug. 1952, pp. 421-424.

Sutherland, "Managing Cancer Through Synergy", *Administrative Radiology Journal*, Nov. 1996, pp. 21-27.

Tjho-Heslinga et al., "Results of ruthenium irradiation of uveal melanoma", *Radiotherapy Oncology*, vol. 29, pp. 33-38, 1993.

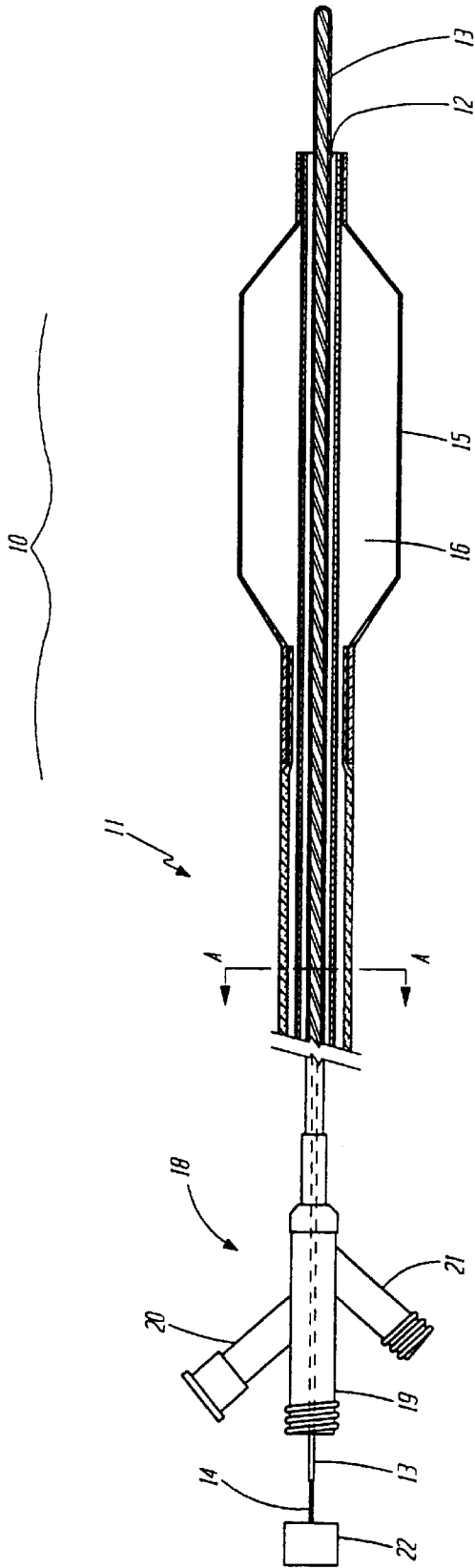

FIGURE 1

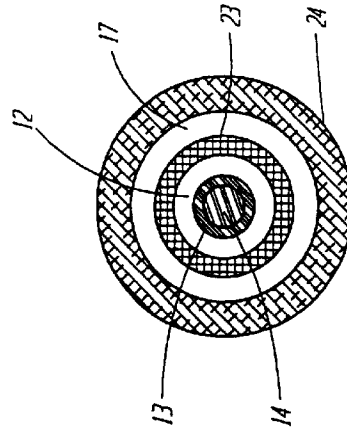

FIGURE 2

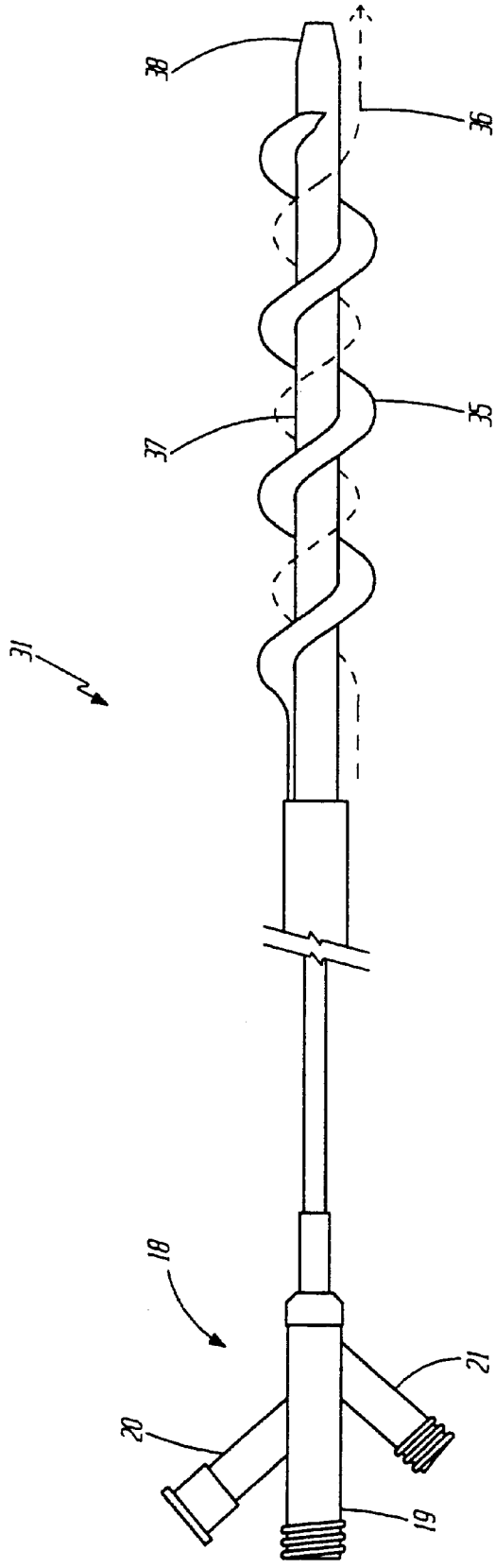

FIGURE 3

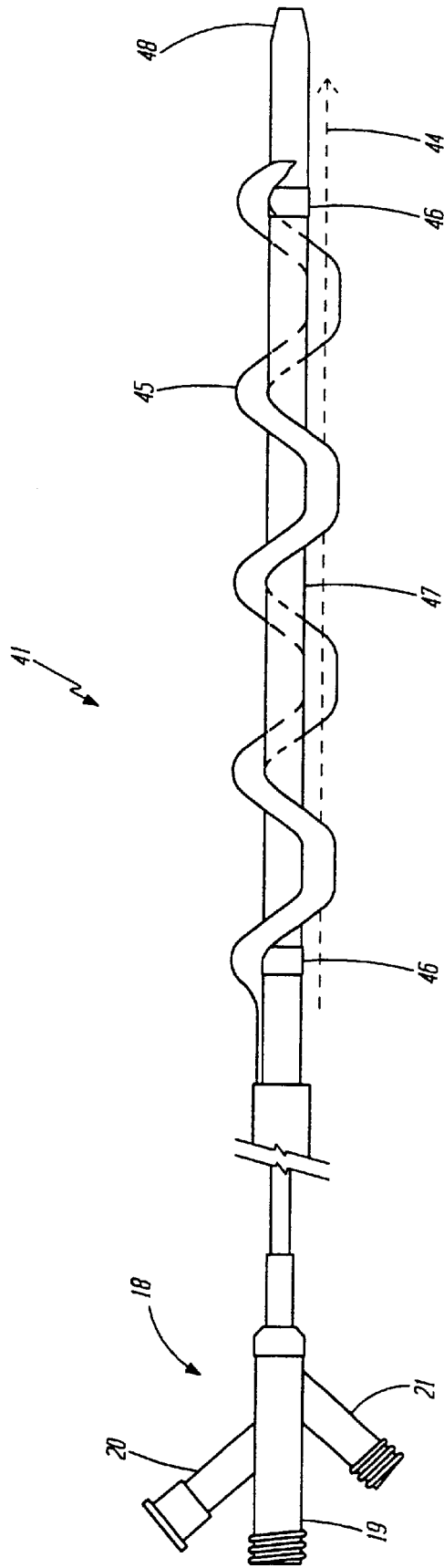

FIGURE 4

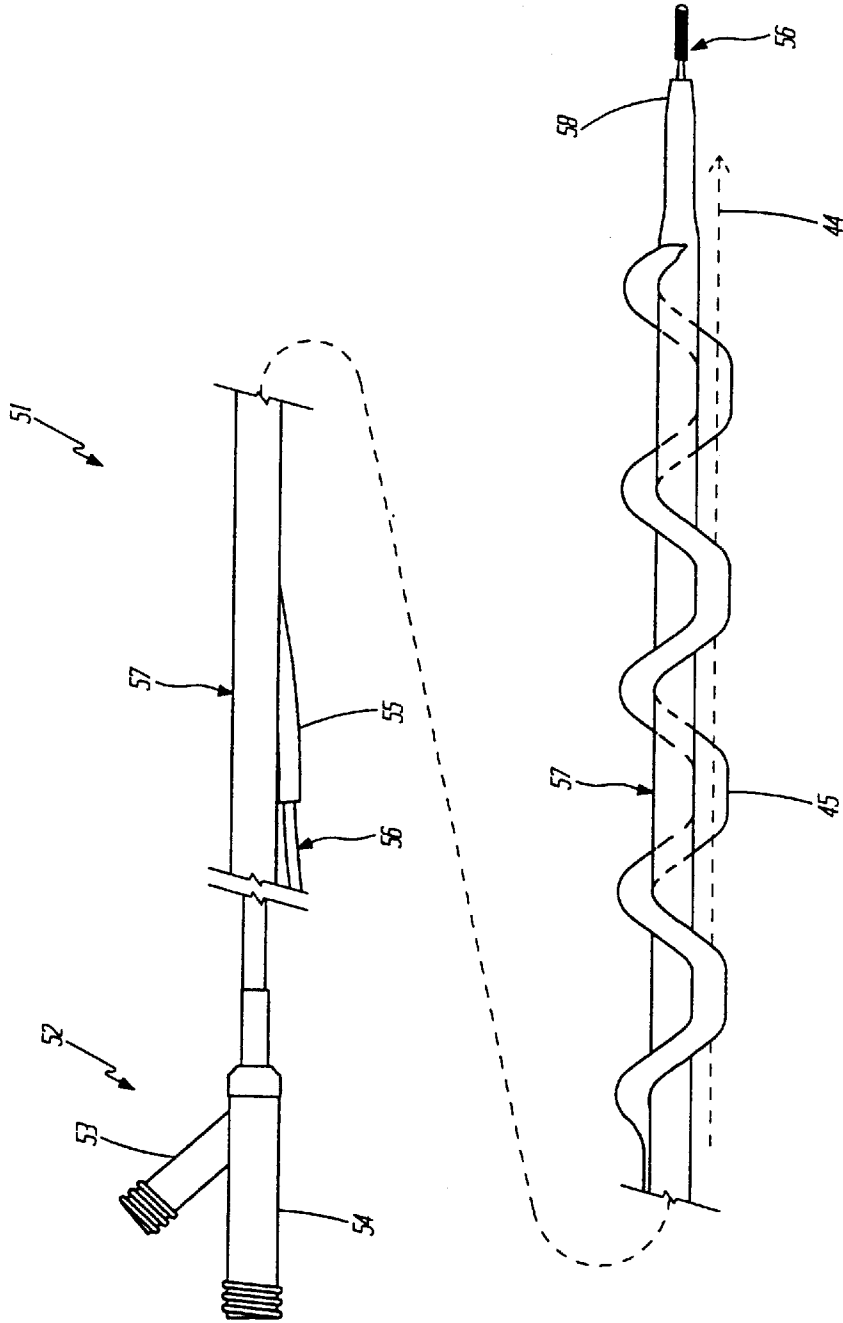

FIGURE 5a



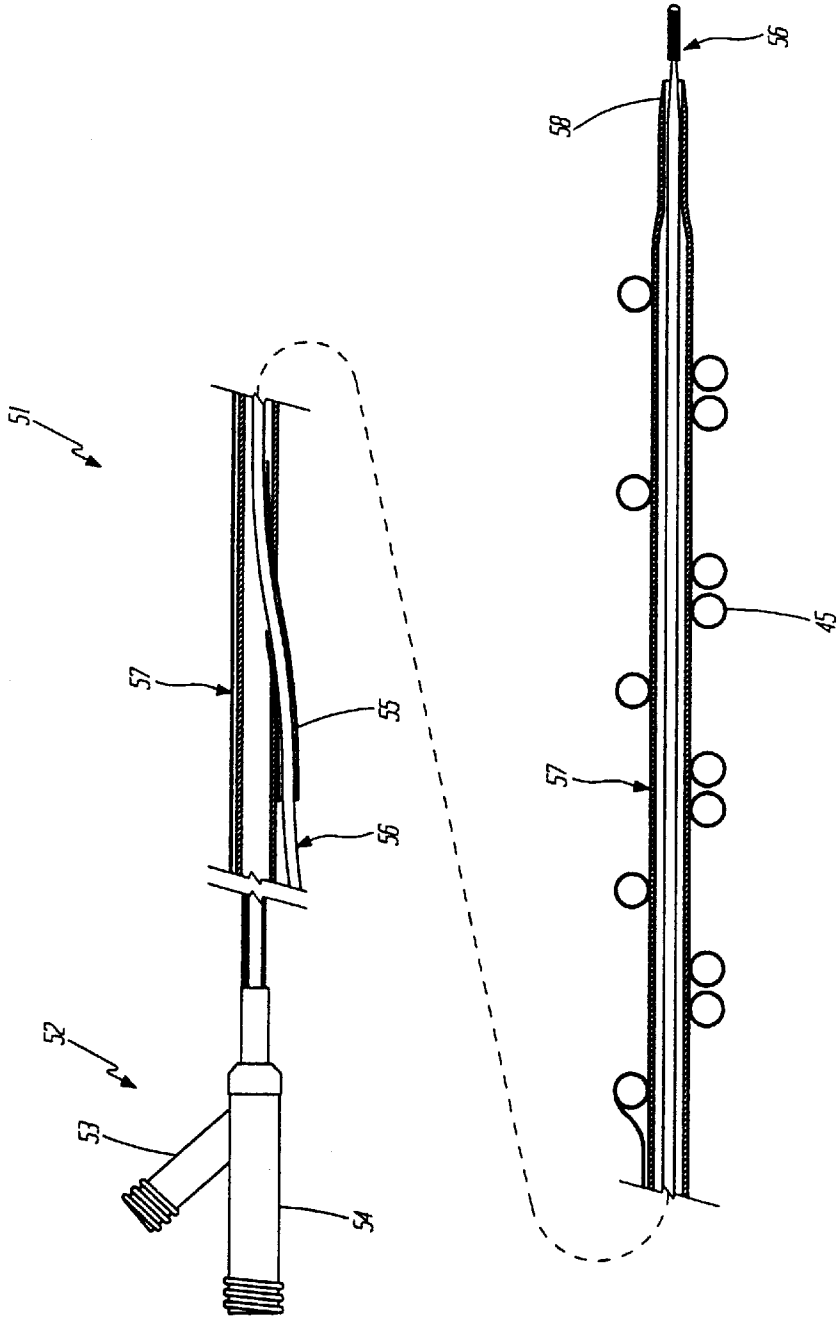

FIGURE 5b

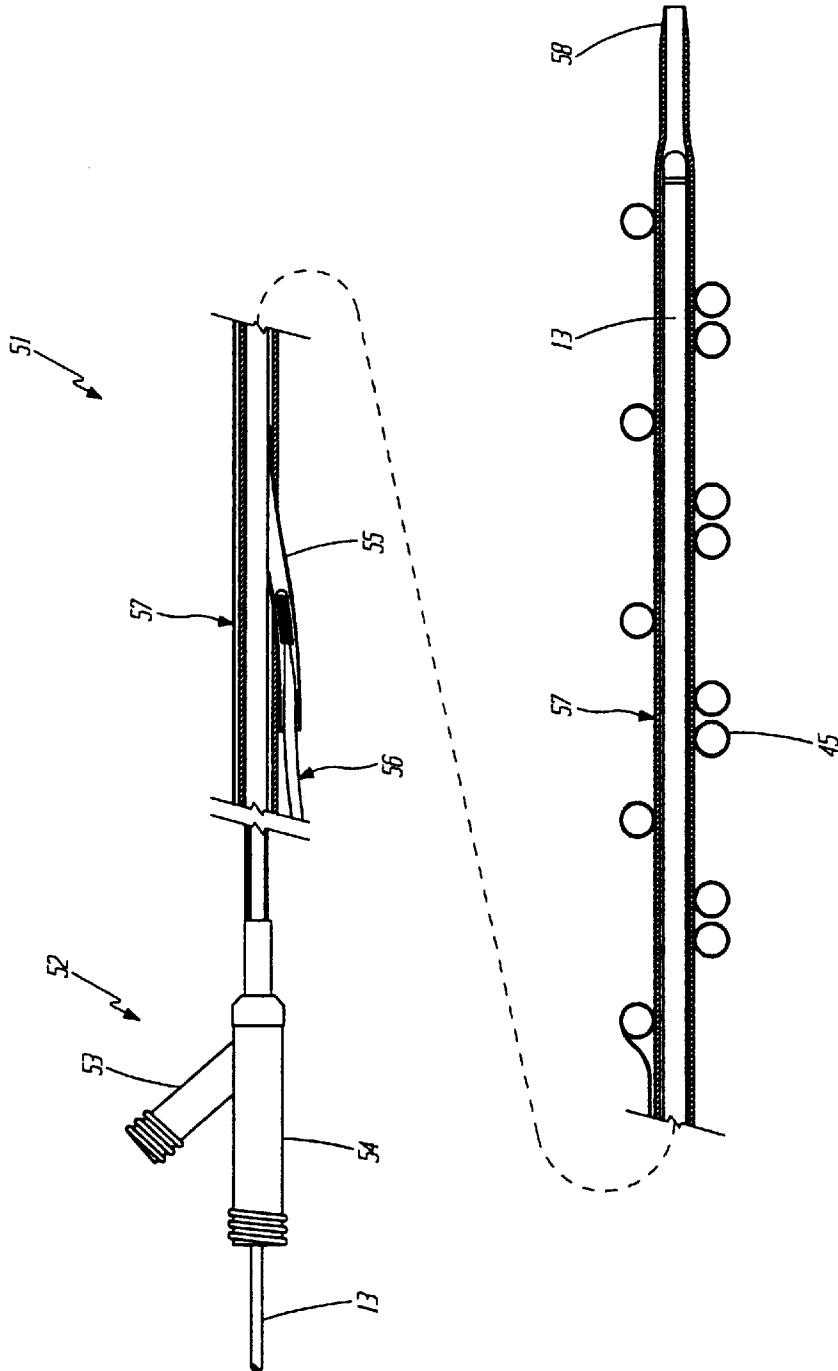

FIGURE 5C

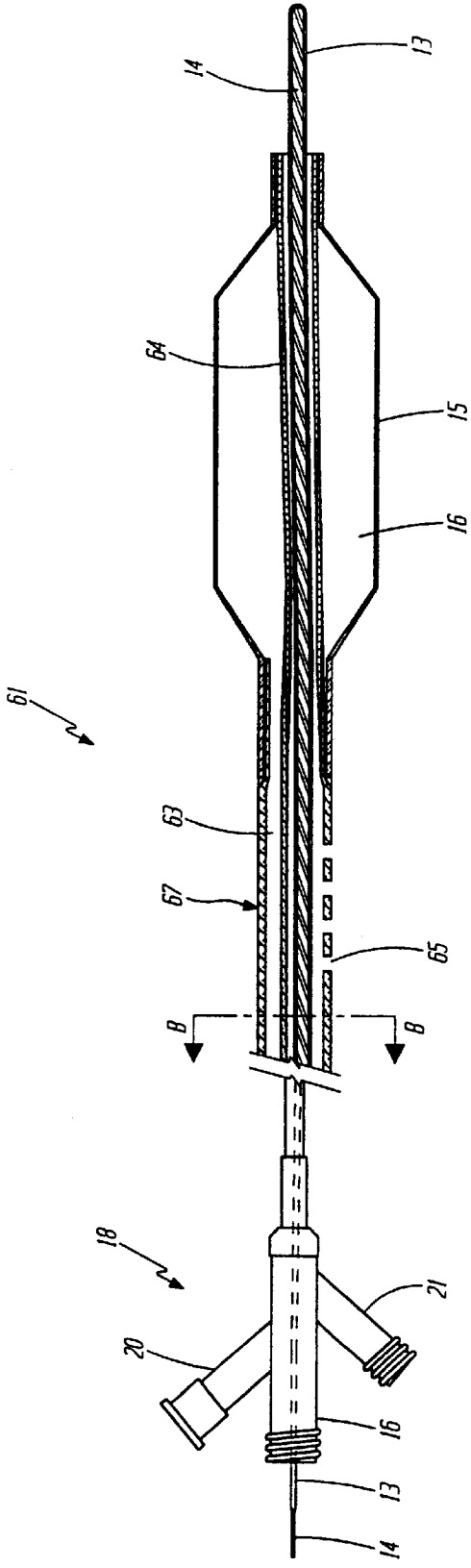

FIGURE 6

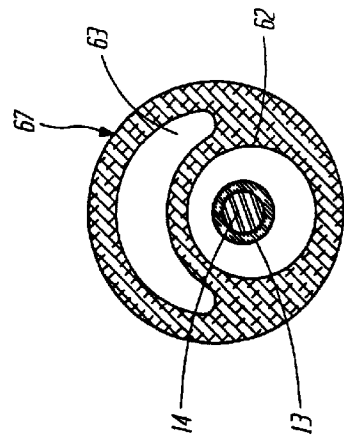

FIGURE 7

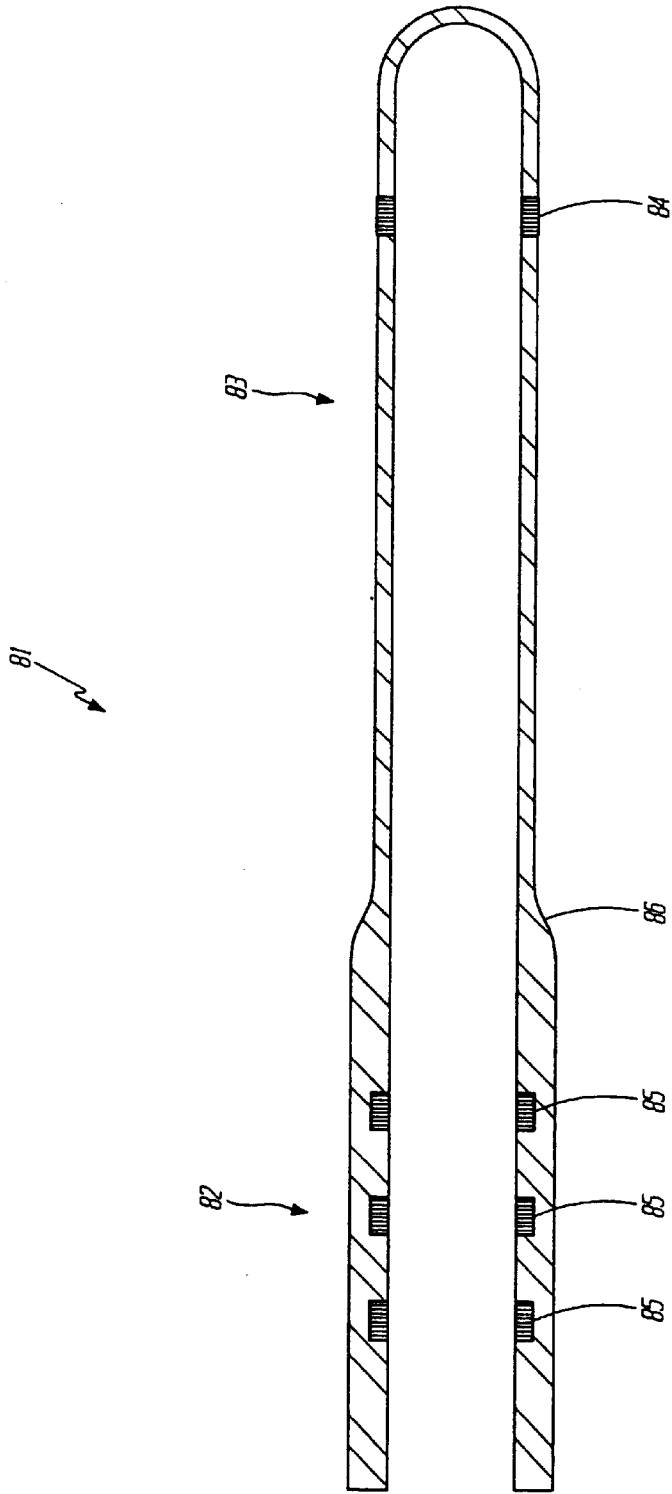

FIGURE 8

# INTRAVASCULAR RADIATION DELIVERY SYSTEM

## CROSS-REFERENCE TO RELATED APPLICATIONS

This application is a continuation of U.S. patent application Ser. No. 08/782,471 filed Jan. 10, 1997 now U.S. Pat. No. 6,234,951, which is a continuation-in-part of co-pending U.S. patent application Ser. No. 08/608,655 filed on Feb. 29, 1996 now U.S. Pat. No. 5,882,290 entitled INTRAVASCULAR RADIATION DELIVERY SYSTEM, the entire disclosure of which are incorporated herein by reference.

## FIELD OF THE INVENTION

The present invention generally relates to intraluminal devices used to deliver radiation inside a living body. More specifically, the present invention relates to intravascular devices used to deliver radiation inside the vasculature of a patient for therapeutic purposes. Those skilled in the art will recognize the benefits of applying the present invention to similar fields not discussed herein.

## BACKGROUND OF THE INVENTION

Intravascular diseases are commonly treated by relatively non-invasive techniques such as percutaneous transluminal angioplasty (PTA) and percutaneous transluminal coronary angioplasty (PTCA). These therapeutic techniques are well-known in the art and typically involve the use of a balloon catheter with a guide wire, possibly in combination with other intravascular devices. A typical balloon catheter has an elongate shaft with a balloon attached to its distal end and a manifold attached to the proximal end. In use, the balloon catheter is advanced over the guide wire such that the balloon is positioned adjacent a restriction in a diseased vessel. The balloon is then inflated and the restriction in the vessel is opened.

Vascular restrictions that have been dilated do not always remain open. For example, the restriction may redevelop over a period of time, a phenomenon commonly referred to as restenosis. Various theories have been developed to explain the cause for restenosis. It is commonly believed that restenosis is caused, at least in part, by cellular proliferation over a period of time to such a degree that a stenosis is reformed in the location of the previously dilated restriction.

Intravascular radiation, including thermal, light and radioactive radiation, has been proposed as a means to prevent or reduce the effects of restenosis. For example, U.S. Pat. No. 4,799,479 to Spears suggests that heating a dilated restriction may prevent gradual restenosis at the dilation site. In addition, U.S. Pat. No. 5,417,653 to Sahota et al. suggests that delivering relatively low energy light, following dilatation of a stenosis, may inhibit restenosis. Furthermore, U.S. Pat. No. 5,199,939 to Dake et al. suggests that intravascular delivery of radioactive radiation may be used to prevent restenosis. While most clinical studies suggest that thermal radiation and light radiation are not significantly effective in reducing restenosis, some clinical studies have indicated that intravascular delivery of radioactive radiation is a promising solution to the restenosis enigma.

Since radioactive radiation prevents restenosis but will not dilate a stenosis, radiation is preferably administered during or after dilatation. European Patent No. 0 688 580 to Verin discloses a device and method for simultaneously dilating a stenosis and delivering radioactive radiation. In particular, Verin '580 discloses balloon dilatation catheter

having an open-ended lumen extending therethrough for the delivery of a radioactive guide wire.

One problem associated with the open-ended lumen design is that bodily fluids (e.g., blood) may come into contact with the radioactive guide wire. This may result in contamination of the bodily fluid and require the resterilization or disposal of the radioactive guide wire. To address these issues, U.S. Pat. No. 5,503,613 to Weinberger et al. proposes the use of a separate closed-ended lumen in a balloon catheter. The closed-ended lumen may be used to deliver a radioactive guide wire without the risk of contaminating the blood and without the need to resterilize or dispose of the radiation source.

The closed-ended lumen design also has drawbacks. For example, the addition of a separate delivery lumen tends to increase the overall profile of the catheter. An increase in profile is not desirable because it may reduce flow rate of fluid injections into the guide catheter and it may interfere with navigation in small vessels.

Another problem with both the open-ended and closed-ended devices is that radiation must travel through the fluid filled balloon in order to reach the treatment site. While this is not a problem for gamma radiation, it poses a significant problem for beta radiation which does not penetrate as well as gamma radiation. Beta radiation is considered a good candidate for radiation treatment because it is easy to shield and control exposure. In larger vessels (e.g., 0.5 cm or larger), a fluid filled balloon absorbs a significant amount of beta radiation and severely limits exposure to the treatment site.

## SUMMARY OF THE INVENTION

The present invention overcomes these problems by providing a radiation delivery system that permits the use of an open-ended delivery lumen without the risk of blood contamination and without the need to dispose of or resterilize the radiation source. In addition, the present invention provides a radiation delivery system that permits beta radiation to be delivered through a balloon without a significant decrease in radiation exposure to the treatment site, even in large vessels.

One embodiment of the present invention may be described as a catheter having an open-ended lumen, a radiation source disposed in the open-ended lumen of the catheter and a closed-end sheath surrounding the radiation source. The closed-end sheath prevents blood and other fluids from coming into contact with the radiation source so that blood is not contaminated and the radiation source may be reused. The catheter may be a balloon catheter and may include a guide wire disposed in the open-ended lumen of the catheter. The open-ended lumen may be a full-length lumen or a partial-length lumen (e.g., a rapid exchange lumen). Preferably, the lumen is centered in the balloon for uniform radiation delivery. The catheter may also include a blood perfusion lumen under the balloon or around the balloon. The open-ended lumen in the catheter may have a reduced diameter adjacent the distal end of the catheter to prevent the radiation source from exiting the lumen. Alternatively, the closed-end sheath may have a ridge which abuts a corresponding restriction in the open-end lumen of the catheter to prevent the radiation source from exiting the lumen.

Another embodiment of the present invention may be described as a method of delivering radiation to a treatment site inside the vasculature of a patient using a the radiation delivery system described above wherein the method

includes the steps of (1) inserting the catheter into the vasculature of a patient; (2) inserting the radiation source into the closed-end sheath; (3) inserting the radiation source and the closed-end sheath into the lumen of the catheter such that the radioactive portion is positioned adjacent a treatment site; and (3) exposing the vascular wall to radiation from the radiation source. Alternatively, the sheath may be inserted into the catheter before the radiation source is loaded into the sheath. The method may also include the steps of (4) removing the radiation source from the catheter; and (5) removing the catheter from the patient. The catheter may be inserted into the vasculature over a guide wire and the guide wire may be removed from the catheter prior to exposing the vascular wall to radiation.

Yet another embodiment of the present invention may be described as a method of delivering radiation to a treatment site inside the vasculature of a patient using a gas-filled balloon catheter and a radiation source wherein the method includes the steps of: (1) inserting the catheter into the vasculature such that the balloon is adjacent to a treatment site; (2) inserting the radiation source into the catheter such that the radioactive portion is adjacent to the balloon; (3) inflating the balloon with a gas; and (4) exposing the treatment site to radiation from the radiation source through the gas in the balloon. The balloon may be inflated prior to or subsequent to inserting the radiation source. Preferably beta radiation is used, but other radioisotopes may be employed.

### BRIEF DESCRIPTION OF THE DRAWINGS

FIG. 1 is a partially sectioned side view of an embodiment of the present invention.

FIG. 2 is a cross-sectional view taken at A—A in FIG. 1.

FIG. 3 is a side view of an alternative embodiment of the present invention including a helical-shaped balloon.

FIG. 4 is a side view of an alternative embodiment of the present invention including a toroidal-serpentine-shaped balloon.

FIGS. 5a, 5b and 5c are partially sectioned side views of an alternative embodiment of the present invention including a rapid-exchange guide wire lumen.

FIG. 6 is a partially sectioned side view of an alternative embodiment of the present invention including a perfusion lumen passing through the balloon.

FIG. 7 is a cross-sectional view taken at B—B in FIG. 6.

FIG. 8 is a cross-sectioned side view of an alternative sheath of the present invention.

### DETAILED DESCRIPTION OF THE INVENTION

The following detailed description should be read with reference to the drawings in which similar parts in different drawings are numbered the same. The drawings, which are not necessarily to scale, depict exemplary embodiments and are not intended to limit the scope of the invention.

Examples of suitable materials, dimensions, parts, assemblies, manufacturing processes and methods of use are described for each embodiment. Otherwise, that which is conventional in the field of the invention may be implemented. Those skilled in the field will recognize that many of the examples provided have suitable alternatives which may also be utilized.

Refer now to FIGS. 1 and 2 which illustrate a radiation delivery system 10 of the present invention. Radiation

delivery system 10 includes a catheter 11 having an open-ended lumen 12 extending therethrough. A closed-ended sheath 13 surrounds a radiation source 14 (such as a guide wire) disposed in the open-ended lumen 12. An after-loader 22 may be connected to the proximal end of the radiation source 14 to advance and retract the radiation source 14 and safely contain it when not in use.

The catheter 11 includes an inflatable balloon 15 having an interior lumen 16 which is in fluid communication with an inflation lumen 17. The catheter 11 illustrated in FIGS. 1 and 2 has a coaxial shaft construction including an inner tube 23 and an outer tube 24. Other shaft constructions may be employed such as a dual lumen shaft design illustrated in FIG. 6. A manifold 18 is connected to the proximal end of the catheter 11 and includes a guide wire port 19 and a flush port 20 both of which are in fluid communication with the open-ended lumen 12. The guide wire port may include a toughy-borst (not shown) to seal about the proximal end of the closed-end sheath 13. The manifold 18 also includes an inflation port 21 which is in fluid communication with the inflation lumen 17 and the interior 16 of the balloon 15.

The closed-end sheath 13 preferably extends to the proximal end of the catheter 11 and may include means for connection to the after-loader 22. The closed-end sheath 13 may be formed of polyethylene, PTFE coated polyimide or other suitable flexible material. The closed-end sheath 13 may have a length of about 100 to 300 cm depending on the length of the catheter 11. A wall thickness between 0.0002 and 0.005 inches is preferred to minimize profile and radiation absorption.

As included with catheter 11 illustrated in FIGS. 1 and 2, the open-ended lumen 12, closed-ended sheath 13, radiation source 14, after loader 22 and toughy-borst are also included with catheters 31, 41, 51 and 61 as illustrated in FIGS. 3, 4, 5 and 6 respectively. In addition, those skilled in the art will appreciate that the various features of each catheter 11, 31, 41, 51 and 61 may be mixed and matched depending on the desired result. For example, the rapid exchange features of catheter 51 may be incorporated into perfusion catheter 61, resulting in a perfusion rapid exchange catheter for the delivery of radiation. As another example, the centering balloon 35 or 45 may be contained inside balloon 15 of catheters 11 and 61 to provide a centering function, even in curved vasculature.

Refer now to FIGS. 3 and 4 which illustrate alternative radiation delivery catheters 31 and 41. Alternative catheters 31 and 41 may be used in place of catheter 11 for the radiation delivery system 10 illustrated in FIG. 1. Except as described herein, the design and use of alternative catheters 31 and 41 is the same as catheter 11. Alternative catheter 41 may be made as described in co-pending U.S. patent application Ser. No. 08/608,655 which is incorporated herein by reference. Similarly, alternative catheter 31 may be made as described in the above-referenced case except that the balloon 35 is wound in a helical shape rather than a serpentine shape.

With reference to FIG. 3, alternative catheter 31 includes a helically-shaped balloon 35 which is wound around the distal end of the catheter 31. When the helically-shaped balloon 35 is inflated, a helically-shaped perfusion path 36 is defined between the balloon 35, the shaft 37 and the inside surface of the blood vessel. The blood perfusion path 36 allows blood to flow across the treatment site while the balloon 35 is inflated. In addition, the concentric and flexible helical shape of the inflated balloon 35 maintains the distal portion of the catheter 31 centered in the vessel, even around

turns in the vasculature. Having the catheter **31** centered in a vessel permits the uniform distribution of radiation to the treatment site.

The distal end of the shaft **37** may include a reduced diameter tip **38** with a corresponding reduced inside diameter open-ended lumen (not visible). The reduced inside diameter permits a conventional guide wire to exit out the distal end of the catheter **31** but prohibits the sheath **13** and radioactive source wire **14** from exiting. This assumes, of course, that the sheath **13** or radioactive source wire **14** is larger than the guide wire. A reduced diameter tip may be included on any of the catheters described herein.

With reference to FIG. 4, alternative catheter **41** includes a toroidal-serpentine-shaped balloon **45**. When the serpentine-shaped balloon **45** is inflated, a linear perfusion path **44** is defined between the balloon **45**, the shaft **47** and the inside surface of the blood vessel. The blood perfusion path **44** allows blood to flow across the treatment site while the balloon **45** is inflated. As with the helical balloon described above, the concentric and flexible serpentine shape of the inflated balloon **45** maintains the distal portion of the catheter **41** centered in the vessel, even around turns in the vasculature. Having the catheter **41** centered in a vessel permits the uniform distribution of radiation to the treatment site. A further advantage of the serpentine-shaped balloon **45** is the relative linearity of the perfusion path **44** which tends to minimize resistance to blood flow.

Catheter **41** may also include two radiopaque markers **46** to facilitate radiographic placement in the vasculature. The distal end of the shaft **47** may include a reduced diameter tip **48** with a corresponding reduced inside diameter open-ended lumen (not visible). The reduced inside diameter permits a conventional guide wire to exit out the distal end of the catheter **41** but prohibits the sheath **13** and radioactive source wire **14** from exiting.

It is also contemplated that both the helical balloon **35** and the serpentine balloon **45** may be covered with an elastomeric sleeve to aid in collapsing the balloon **35/45** upon deflation. This sleeve would be connected to the shaft adjacent the proximal and distal ends of the balloon **35/45**. It is further contemplated that this sleeve may include perfusion holes both proximally and distally to permit blood perfusion along the perfusion path **36/44** defined by the balloon **35/45**. If a gas is used to inflate the balloon **35/45** in large diameter vessels (e.g., peripheral vasculature), it is preferred to not permit perfusion of blood which would otherwise absorb beta radiation. In such a situation, the sleeve would not include perfusion holes.

Refer now to FIGS. **5a**, **5b** and **5c** which illustrate a rapid-exchange embodiment of the present invention. Alternative catheter **51** may be used in place of catheter **11** for the radiation delivery system **10** illustrated in FIG. 1. Except as described herein, the design and use of alternative catheter **51** is the same as catheter **11**.

Rapid-exchange catheter **51** includes an elongate shaft **57** with a manifold **52** connected to the proximal end and a balloon **45** connected to the distal end. Although catheter **51** is shown with a serpentine balloon **45** and a corresponding linear perfusion path **44**, any of the balloon types described herein may be used.

The manifold **52** includes a balloon inflation port **53** which is in fluid communication with the balloon **45** via a conventional inflation lumen. A radiation source entry port **54** is also included in the manifold **52**. The entry port **54** communicates with the open-ended lumen and permits the insertion of the sheath **13** and radiation source **14**. The

open-ended lumen terminates in a reduced diameter tip **58** which permits a conventional guide wire **56** to exit out the distal end of the catheter **51** but prohibits the sheath **13** and radioactive source wire **14** from exiting.

The guide wire **56** enters the shaft **57** at the proximal guide wire tube **55**. The guide wire tube **55** is located near the distal end of the catheter to permit catheter exchange without the need for an extension wire or wire trapping device. As best seen in FIG. **5c**, the guide wire tube **55** has sufficient length such that the guide wire **56** may be pulled back and out of the open-ended lumen. In particular, the distance from the proximal end of the guide wire tube **55** to the distal end of the catheter **51** is less than the length of the guide wire extending outside of the patient's body. With the guide wire pulled back, the radioactive source wire **14** and the sheath **13** may be inserted into the entry port **54** to the distal end of the catheter **51**.

Refer now to FIGS. **6** and **7** which illustrate an alternative perfusion catheter **61**. Alternative catheter **61** may be used in place of catheter **11** for the radiation delivery system **10** illustrated in FIG. 1. Except as described herein, the design and use of alternative catheter **61** is the same as catheter **11**.

Perfusion catheter **61** includes an elongate shaft **67** with a manifold **18** connected to the proximal end and a balloon **16** connected to the distal end. The shaft **67** is a multi-lumen type extrusion including an open-ended lumen **62** and an inflation lumen **63**. Inflation lumen **63** provides fluid communication between the inflation port **21** and the interior of the balloon **16**. Open ended lumen **62** is in communication with entry port **19** for the insertion of a guide wire (not shown) or the radioactive source **14** and sheath **13**. A guide wire extension tube **64** is connected to the distal end of the multi-lumen shaft **67** and rigidly connects to the distal end of the balloon **15**.

Catheter **61** includes a series of perfusion ports **65** which are in fluid communication with the distal portion of the open-ended lumen **62**. The perfusion ports **65** permit blood to flow across the treatment site via the open-ended lumen while the balloon **15** is inflated.

With reference now to FIG. **8**, an alternative sheath **81** is illustrated. Alternative sheath **81** may be used in place of sheath **13** for the radiation delivery system **10** illustrated in FIG. 1. Except as described herein, the design and use of alternative sheath **81** is the same as sheath **13**.

Sheath **81** includes a proximal portion **82** and a distal portion **83**, wherein the proximal portion **82** includes a relatively thicker wall and larger outside diameter. The thicker wall tends to absorb radiation to reduce the amount of unwanted exposure, particularly exposure of the medical personnel. The larger outside diameter of the proximal portion **84** may be used in conjunction with a corresponding restriction in the open-ended lumen **12** of any of the catheters described herein. Specifically, the leading edge or ridge **86** of the proximal portion **82** may abut a mating restriction in the open-ended lumen **12** such that the sheath **81** cannot be advanced beyond that point. The leading edge **86** and the mating restriction in the open-ended lumen serve the same function as the reduced diameter tip described previously and may be used in lieu thereof. In other words, the leading edge **86** and the mating restriction in the open-ended lumen would permit a conventional guide wire **56** to exit out the distal end of the catheter but would prohibit the sheath **81** and radioactive source wire **14** from exiting the distal end of the catheter.

The closed-end sheath **81** may include means for connection to the after-loader **22**. The closed-end sheath **81** may be

formed of polyethylene, PTFE coated polyimide or other suitable flexible material. The closed-end sheath **81** may have a length of about 100 to 300 cm depending on the length of the catheter **11**. On the distal portion **83**, a wall thickness between 0.0002 and 0.005 inches is preferred to minimize profile and radiation absorption. On the proximal portion **82**, a wall thickness between 0.040 and 1.0 inches is preferred to maximize radiation absorption without significantly compromising profile. The outside diameter of the proximal portion **82** may be greater than the vascular access size on the portion of the sheath **81** that remains outside the body. Once the radiation source is inside the body, the risk of exposure of beta radiation to medical personnel is diminished.

Sheath **81** may also include a radiopaque marker **84** to facilitate radiographic placement of the sheath **81** and radioactive wire **14**. Such a radiopaque marker **84** may also be included on sheath **13**.

Sheath **81** may also include a series of annular magnets **85**. Magnets **85** may be used to interact with a series of magnets connected to the catheter **11**, **31**, **41**, **51** or **61** or a series of magnets connected to a guide catheter (not shown). This general arrangement is described in more detail in PCT publication WO 95/21566 which is fully incorporated herein by reference. The interacting magnets provide a means to longitudinally control and stabilize the position of the radiation source relative to the patient and treatment site.

In practice, catheters **11**, **31**, **41**, **51** and **61** may be used to deliver radiation to the vascular wall in the following manner. After vascular access is established and a guide catheter is in position (if desired), the catheter **11/31/41/51/61** is inserted into the patient with the distal portion adjacent the treatment site. If a guide wire is used, the guide wire may be inserted prior to or simultaneously with the catheter. The balloon is then inflated to a low pressure sufficient to center the balloon in the vasculature and prevent movement of the catheter relative to the treatment site. Optionally, the balloon may first be inflated to a higher pressure in order to dilate the treatment site. If desired, the balloon may be inflated with a gas such as nitrogen, carbon dioxide or other non-toxic gas to minimize the absorption of radiation by the inflation media. After dilatation, the balloon is maintained in an inflated state, preferably at a low pressure, to center the catheter in the vascular lumen. The sheath **13** is placed over the radiation wire **14**, preferably ahead of time, and the two are advanced into the open-ended lumen using an after-loader system. Optionally, the sheath **13** is first loaded into the open-ended lumen of the catheter and the proximal end of the sheath is connected to the after-loader, followed by insertion of the radioactive source wire **14**. The toughy-borst is maintained sufficiently loose to allow advancement and may be locked to fully seal about the sheath **13** once the radiation wire **14** and sheath **13** are in the desired position. If a guide wire is used in the open-ended lumen, the guide wire is preferably retracted to permit passage of the radioactive wire **14** and sheath **13**. If a rapid exchange catheter **51** is used, the guide wire is pulled back into the proximal guide

wire tube **55**. The vascular wall is then exposed to radiation (preferably beta radiation) for the desired period of time. The radioactive wire **14** and sheath **13** are removed from the catheter **11/31/41/51/61** and the catheter is removed from the patient.

While the specification describes the preferred embodiments, those skilled in the art will appreciate the spirit and scope of the invention with reference to the appended claims. Claims directed to methods of the present invention may be read without regard as to the order of the steps unless contraindicated by the teachings herein.

What is claimed is:

1. An intravascular catheter system, comprising:
  - an elongate catheter including a distally disposed balloon, a radiation source lumen having an open distal end and a perfusion path, the balloon having a non-linear shape and the perfusion path having a linear shape; and
  - an elongate radiation source disposed in the radiation source lumen.
2. An intravascular catheter system as in claim 1, wherein the perfusion path is defined in part by the balloon.
3. An intravascular catheter system as in claim 1, wherein the balloon is gas-filled.
4. An intravascular catheter system as in claim 1, wherein the elongate radiation source is disposed in a sheath.
5. An intravascular catheter system as in claim wherein the sheath has a closed distal end.
6. An intravascular catheter system as in claim 5, wherein the sheath has a wall thickness of between 0.0002 inches and 0.005 inches.
7. An intravascular catheter system, comprising:
  - an elongate catheter including a distally disposed balloon, a radiation source lumen, the balloon having a non-linear shape; and
  - an elongate sheath disposed in the radiation source lumen, the sheath having a wall thickness of between 0.0002 inches and 0.005 inches; and
  - an elongate radiation source disposed in the sheath.
8. An intravascular catheter system as in claim 7, wherein the sheath has a closed distal end.
9. An intravascular catheter system as in claim 8, wherein the radiation source lumen has an open distal end.
10. An intravascular catheter system as in claim 7, wherein the catheter includes a perfusion path.
11. An intravascular catheter system as in claim 10, wherein the perfusion path has a linear shape.
12. An intravascular catheter system as in claim 11, wherein the perfusion path is defined in part by the balloon.
13. An intravascular catheter system as in claim 7, wherein the balloon is gas-filled.
14. The intravascular catheter of claim 1, wherein the perfusion path is thin the radiation source lumen.
15. The intravascular catheter of claim 10, wherein the perfusion path is within the radiation source lumen.

\* \* \* \* \*



UNITED STATES PATENT AND TRADEMARK OFFICE  
**CERTIFICATE OF CORRECTION**

PATENT NO. : 6,599,230 B2  
DATED : July 29, 2003  
INVENTOR(S) : R.N. Hastings et al.

Page 1 of 2

It is certified that error appears in the above-identified patent and that said Letters Patent is hereby corrected as shown below:

Title page,

Item [56], **References Cited**, U.S. PATENT DOCUMENTS, insert in appropriate order:

-- 6,090,035	7/2000	Campbell et al.
6,099,455	8/2000	Columbo et al.
6,106,454	8/2000	Berg et al.
6,110,097	8/2000	Hastings et al.
6,117,065	9/2000	Hastings et al.
6,142,926	11/2000	Schneiderman
6,146,322	11/2000	Papirov et al.
6,149,574	11/2000	Trauthen et al.
6,149,575	11/2000	Leonhardt
6,152,869	11/2000	Park et al.
6,162,165	12/2000	Apple et al.
6,179,768	1/2001	Loffler et al.
6,200,256	3/2001	Weinberger
6,200,257	3/2001	Winkler
6,200,307	3/2001	Kasinkas et al.
6,203,485	3/2001	Urick
6,213,976	4/2001	Trerotola
6,217,503	4/2001	Weinberger et al.
6,224,535	5/2001	Chiu et al.
6,224,536	5/2001	Pike
6,231,495	5/2001	Denk
6,231,719	5/2001	Garvey et al.
6,234,952	5/2001	Lipric
6,238,332	5/2001	Kanesaka
6,241,719	6/2001	Wallace et al.
6,248,057	6/2001	Mavity et al.
6,251,059	6/2001	Apple et al.
6,254,552	7/2001	Lewis et al.
6,258,019	7/2001	Verin et al.
6,261,219	7/2001	Meloul et al.
6,264,579	7/2001	Odai et al.
6,264,595	7/2001	Delfino et al.
6,264,596	7/2001	Weadock
6,264,598	7/2001	Armini
6,267,717	7/2001	Stoll et al.
6,267,775	7/2001	Clerc et al.
6,283,910	9/2001	Bradshaw et al.
6,283,911	9/2001	Keren --

UNITED STATES PATENT AND TRADEMARK OFFICE  
**CERTIFICATE OF CORRECTION**

PATENT NO. : 6,599,230 B2  
DATED : July 29, 2003  
INVENTOR(S) : R.N. Hastings et al.

Page 2 of 2

It is certified that error appears in the above-identified patent and that said Letters Patent is hereby corrected as shown below:

Title page (cont's),

Item [56], **References Cited**, FOREIGN PATENT DOCUMENTS, insert in appropriate order :

-- WO WO 01/60443 A1 8/2001  
WO WO 01/54764 A2 8/2001  
WO WO 01/47602 A1 7/2001  
WO WO 01/26734 A1 4/2001  
WO WO 01/21248 A1 3/2001  
WO WO 01/21245 A1 3/2001  
WO WO 01/21106 A1 3/2001  
WO WO 01/14617 A1 3/2001  
WO WO 01/14011 A1 3/2001  
WO WO 00/76557 12/2000  
WO WO 00/74778 12/2000  
WO WO 00/69503 11/2000  
WO WO 00/56249 9/2000  
WO WO 00/45627 8/2000  
WO WO 00/32271 6/2000  
JP 2000024001 1/2000 --; and

OTHER PUBLICATIONS, "Raloff" reference, " "Diease", " should read -- *Disease*", --

Column 8,

Line 27, "as in claim wherein" should read -- as in claim 4, wherein --

Line 54, "thin" should read -- within --

Signed and Sealed this

Third Day of August, 2004

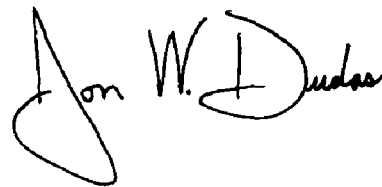

JON W. DUDAS  
*Acting Director of the United States Patent and Trademark Office*